

CI/SfB	(22.3)	x	K2
--------	--------	---	----

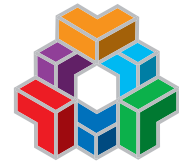

tenon
PARTITIONS



ovation

Innovation & design



	BOARD ROOMS	EXECUTIVE OFFICE SUITES	RECEPTION AREAS	CONFERENCE SUITES	GENERAL OFFICE	CLEAN ROOM	LIGHT INDUSTRIAL
Areas of use	4	4	4	4	4	4	4
Fire performance	Solid modules - up to 30 minute fire rating. Glazed modules - up to 30 minute fire rating in both offset single and double glazed applications. Door modules - up to 30 minute fire rating.						
Acoustic performance	Solid modules - standard construction - up to 43dB. Glazed modules - standard construction - up to 42dB. Door modules - standard solid door core - up to 30dB.						
Construction Options	Solid modules - standard construction is with 12.5mm plasterboard panels with a wide choice of finishes together with joint and trim options. Glazed modules - includes offset single and double glazing incorporating bi-element construction and the option of integral transoms and venetian blinds. Door modules - standard frames are supplied to suit 1981 x 838 x 44mm doors. Frames will also accept most door types including glass and aluminium.						
Max Construction Heights	Solid modules - standard construction - up to 3000mm. Glazed modules - maximum recommended height using standard sections - 3000mm.						



The result of extensive research and development has provided a state-of-the-art partitioning system, offering designers and installers the vertical solution for today's discerning market.

Style

Ovation has been designed to suit many different environments. It's styling provides gently radiused upright posts and door frames with a choice of either recessed or flush skirting.

The system is available in an almost unlimited choice of RAL or BS coloured finishes to compliment any interior design scheme.

Flexibility

Ovation locks together with ease and uses a push-fit, easy to use interpanel trim system which dispenses with the need for vertical fixings. The system also accommodates the standard wall details of pencil line, 'V' joint and taped joint. The latter offering a monolithic flush face effect.

Used creatively Ovation provides the building blocks for today's discerning client.



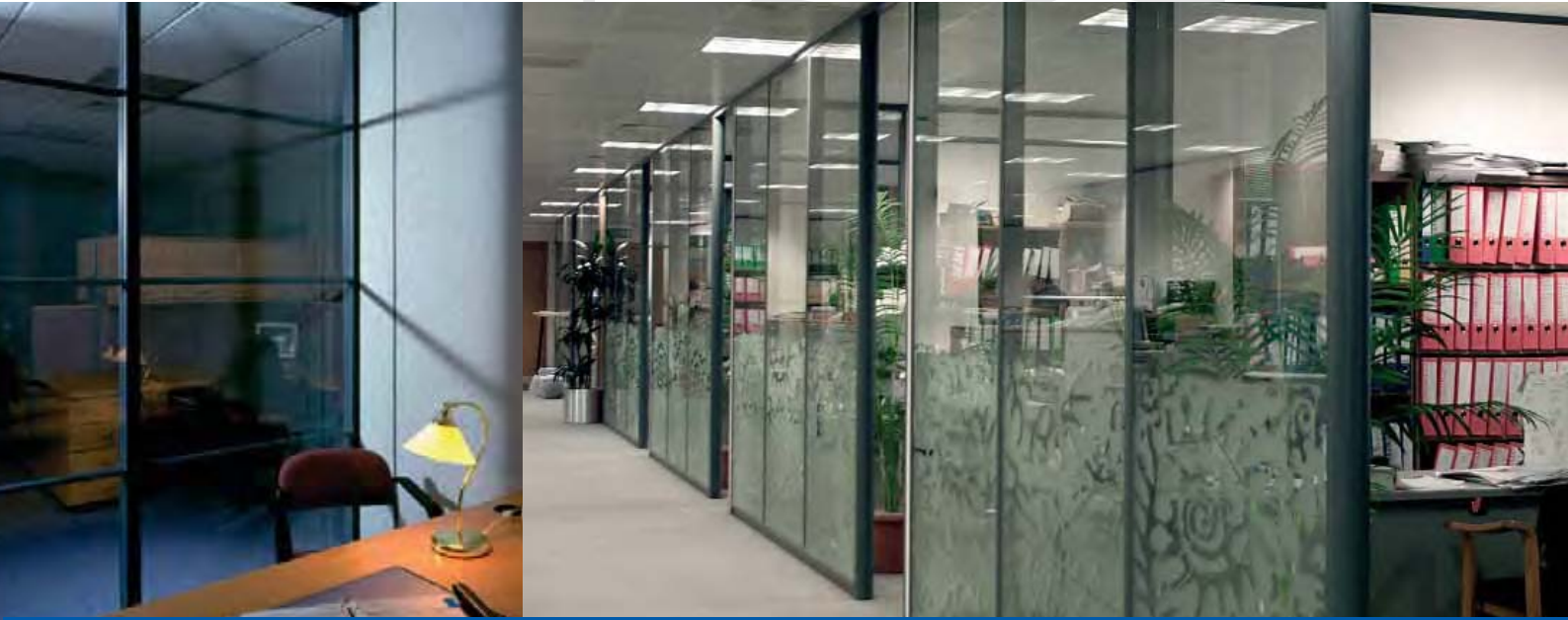

*All verticle glazed elevations
are pre-manufactured.*

*Ovation complies with BS5234
- giving it a medium duty
classification for load testing
and deeming it suitable to
withstand a medium degree of
crowd pressure.*

Adaptability

Designed for fast and easy installation, the introduction of Tenon Bi-element construction offers the end user rapid on-site assembly without lengthy lead times.

Safe and strong; the system provides great flexibility. The absence of vertical fixings combined with Tenon Bi-element construction makes it simple to install and straightforward to dismantle and re-assemble.

Innovation

Glazing is available in a number of different configurations. Modules being either offset single or double glazed - the choice is yours. Ovation's innovative integral transom feature offers an attractive alternative to the standard "oriental" or banded glazing. Where blinds are required, Ovation's ceiling head feature is designed to conceal the 25mm blind mechanism within the partition, providing a neat and practical way to ensure that only the vanes are visible.

For more information or advice on this system's performance please contact the Tenon Technical Department.



Fire

Safety is a key feature of Ovation. The system has been thoroughly tested and offers 30 minute fire resistance to BS476 part 22, 1987, on full height single and double glazing elevations. This also applies to door modules and solid elevations, regardless of the board joint details.

Acoustics

Acoustics is another major performance consideration and again Ovation passes the test. Solid construction offers sound attenuation values of up to - 43dB (R_w), with glazing offering attenuation values of up to - 42dB (R_w) under laboratory conditions.

Ovation is only one of our range of partition systems. Each designed to provide a verticle solution for all building environments. Systems for fire, acoustic, clean room, washroom or special applications are readily available from the Tenon range.

To compliment Tenon Fire & Sound, the Nexus range of ironmongery offers a wide choice of door furniture in a variety of finishes.



The major components of the Ovation partition system are a steel head channel, ovation stud section, pre-fabricated combined steel and aluminium glazing frames, aluminium door and base section together with aluminium or plastic push-fit Interpanel trims.

Tenon Ovation is 78mm thick overall and based on a module width of 1209mm. Where necessary glazing frames can be manufactured to suit customer requirements.

Construction

When constructed in accordance with company instructions the system can be used up to a height of 3000mm using standard stud sections and push fit trims. All partitions should be constructed with studs at 600mm centres with staggered joints in fire rated applications.

Appearance

Aluminium and visible steel profiles are supplied in a range of twelve standard colours:

RAL 5010 Gentian Blue	RAL 9010 Pure White
RAL 5012 Light Blue	RAL9016 Traffic White
RAL 6005 Moss Green	BS:00 A 05 Light Grey
RAL 7011 Iron Grey	BS:04 E 53 Geranium Red
RAL 9005 Jet Black	BS:08 B 15 Magnolia
RAL 9006 Silver	BS:08 B 29 Van Dyke Brown

Standard BS 4800 and RAL colours not included in the above list are available, however, these may be subject to longer lead times and additional costs.

A full suite of trim sections is available in both plastic and aluminium. The plastic trims are available in two standard colours Light Grey BS00A05 and Dark Grey RAL 7011 but may be coated to match or contrast the colour of the main framework.

Panels

Tenon Ovation can be supplied with a wide variety of panel options. The standard panel type is vinyl faced negative edge plasterboard, but depending on the performance criteria panels can be supplied to suit a wide variety of applications using alternative panel

substrates including plasterboard, chipboard, MDF, Gypsum Fibreboard, moisture resistant plasterboard etc. These substrates can in turn be laminated with a diverse range of facings to allow their use in specialist areas.

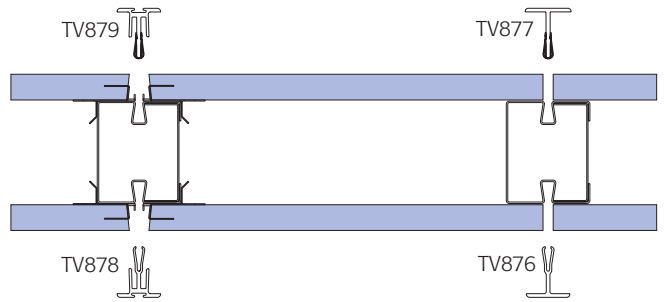

Tenon Bi-element construction with push fit trim sections

Facings available include high pressure laminates, plastisol, PVF2 colour coat steel, galv steel and Vinyl covered galv steel for use as magnetic walls. Panels are fitted within the system using a patented board edge clip and push-fit interpanel trim section, which provides individual panel releasability.

If pencil line joints or bevelled joints are preferred then Tenon Scion board edge clips can be used. However the system then loses it's releasable solid panel element as the partition must be sequentially built.

Glazing

Glazing is carried out using the Tenon bi-element method of construction. Pre-fabricated glazing panels are supplied with or without glass and are installed individually from either side of the partition to create double glazing. Alternatively a pre-assembled blanking frame can be used on one side of the partition for single off-set glazing. Integral transoms can be included within both types of frames to create a banded glazing effect that requires no additional fixing on site. All frames are manufactured to suit individual contracts, so accurate site dimensions are required when ordering. The maximum allowable glazing tolerance for the system is (+10 / -20mm) on the height only.

Ovation integral transom detail

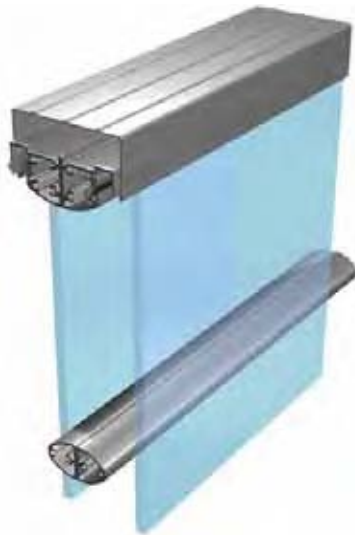

Glass with a thickness of between 6mm and 9mm can be accommodated within the system allowing the use of a range of both toughened and laminated glasses including specialist acoustic products. The system of glazing used for Ovation is inherently fire rated and as such does not require the use of any form of intumescent or additional steel lining. Please check with the Technical department to ensure that the appropriate type of glass has been chosen to achieve the specified level of protection or performance.

Venetian Blinds

The maximum internal void within the system is 61mm it therefore easily, accommodates the standard range of venetian blinds. The head glazing and blanking sections have been designed with a

recess so that the blind control track is not visible once fitted. The control knob and cable can either be fitted within the standard steel stud section or in the purpose designed cable management post. Fixing instructions are available for both methods of construction from the Tenon Technical Department.

Ovation recessed blind channel detail

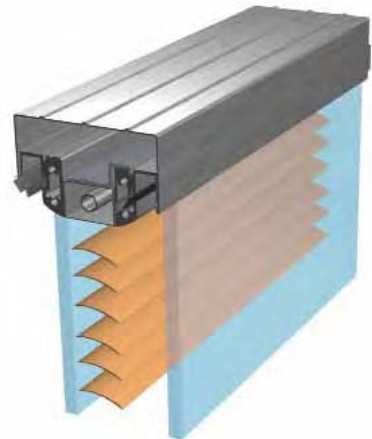

Cable management post assembly with control - Double glazed example

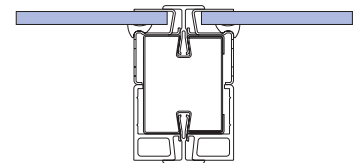

Standard stud with control - Single glazed example

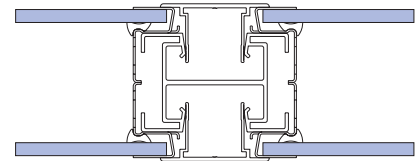

Door Modules

Standard door frames are supplied in a universal format (i.e. left or right handed) and come pre-cut, complete with three factory fitted hinges, Tenon lock box, door seal and pre-cut steel transom. For fire rated applications intumescent strip (TV895) is also included whereas in non-rated situations a dummy intumescent (TV896) is provided to conceal all frame fixings.

Standard height door frames are supplied with mitred frame section (TV860) as the door head. In addition to intumescent strip a door self-closer must be fitted to conform with fire test certification. The Tenon door gasket has been tested as a smoke seal and complies with BS476 part 31.1.

Sound

Tenon Ovation has been thoroughly tested in accordance with BS2750 : Part 3 : 1980(1993) : (ISO 140/111-1978) The results achieved rated in accordance with BS 5821 1 1984 : (ISO 717/1 - 1978).

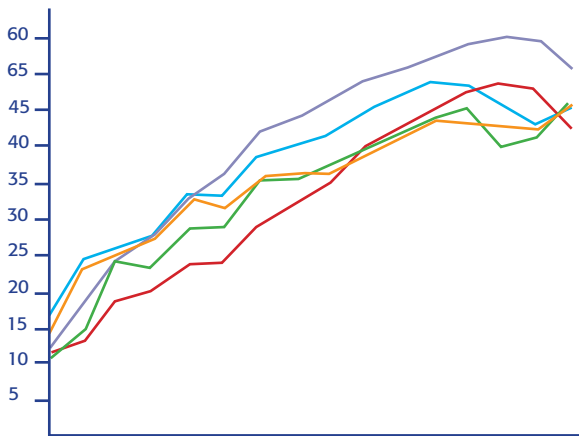

TEST 1	Single 12.5mm plasterboard each side with no quilt in the internal void.	34dB _(RW)
TEST 2	Single 12.5mm plasterboard each side with 50mm (45kg/m ³) mineral fibre insulation in the internal void,	43dB _(RW)
TEST 3	Double glazed using 6.4mm laminated and 6mm toughened glass.	38dB _(RW)
TEST 4	Double glazed using 6.4mm laminated and 8.8mm laminated glass.	40dB _(RW)
TEST 5	Double glazed using 7mm and 9mm Acoustic Laminate.	42dB _(RW)

The above results were obtained across the frequency range 100 / 3150 Hz.

It should be noted that all the above results were obtained under laboratory test conditions. The expected level of performance should take into account the type of ceiling, ducting, flooring, the inclusion of doors, glazing and the level of background noise present. The leakage of Sound through poorly insulated parts of the partition may have a significant effect on the level of attenuation possible.

Fire

Tenon Ovation has been thoroughly tested for fire performance and when installed in accordance with company instructions provides half hour fire protection to B.S. 476 part 22, 1987. Where glazed screens are installed in fire rated partitions **it is the responsibility of the installer** to ensure that the area and location of the glass is acceptable to the Local Authority and Building Control Department.

Test evidence allows to offer 30 minute fire rating on

Doors Single Leaf
Leaf and Overpanel
Full height leaf

Solid Panels Continuous runs of 12.5mm plasterboard

Glazing Single and double glazed modules up to a maximum of 3.15M² using either Pyroshield or Pyran as the fire rated glass with a choice of 6.4mm laminate or 6mm toughened as the sacrificial pane. Not all fire rated glasses are suitable for use within the system, please check with Tenon Technical Department for details.

Stability

In accordance with BS 5234, Tenon Ovation has been subjected to a number of stability tests that allow us to classify the system Medium Duty as laid down in the standard.

The system successfully passed BS 5234 Part 2 Annexes A to F, meeting the test performance levels to the required grades. In addition to the tests on a straight run of partition, a corner junction was also tested again meeting the necessary criteria.

Under Annex G, Ovation was tested to determine it's resistance to crowd pressure and passed at a level of 1.5kN/m. When tested to failure the maximum load achieved was 1.65kN/m.

Solid panel joint options

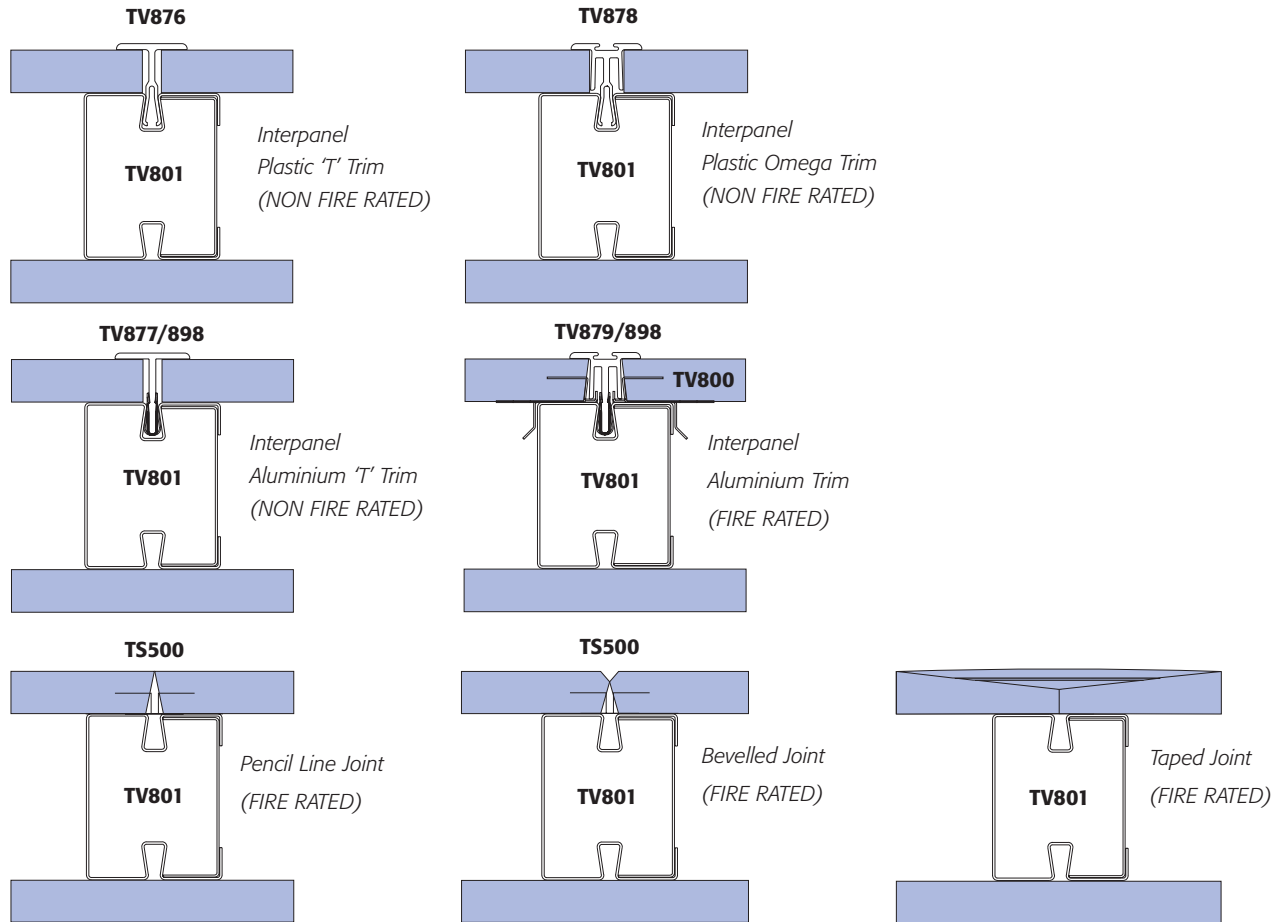

When using Ovation's push fit plastic and aluminium trim sections, individual solid and glazed panels can be demounted without the need to dismantle full partition runs. When specifying solid modules with pencil line, bevelled or taped joints only glazed modules can be removed or changed independently as solid panels must be removed sequentially.

In fire rated applications, only aluminium trims and negative edge plasterboard can be used, with the Interpanel 'T' Trim (TV877) only suitable for use at door frames and in part glazed modules.

Where the Ovation panel edge clip is to be used only negative edge plasterboard can be specified as the normal square edge board is unsuitable.

Door Frame joint options

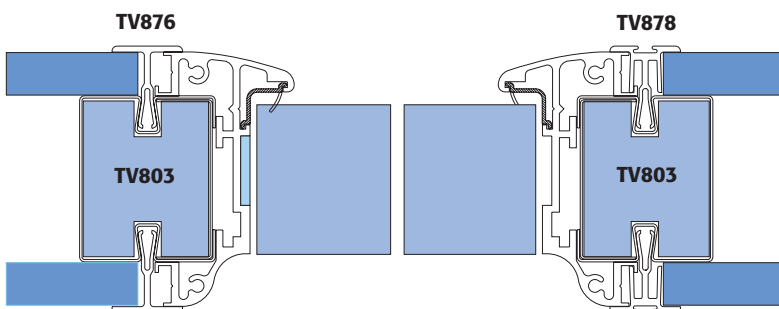

Two types of trim are suitable for use at door frames:

- A - Interpanel 'T' trim (TV876 / 877)
- B - Interpanel Omega trim (TV878 / 879)

This is because the chosen trim must fit flush with the skirting section. Both of the aluminium trims TV877 and TV879 are suitable for use in fire rated applications.

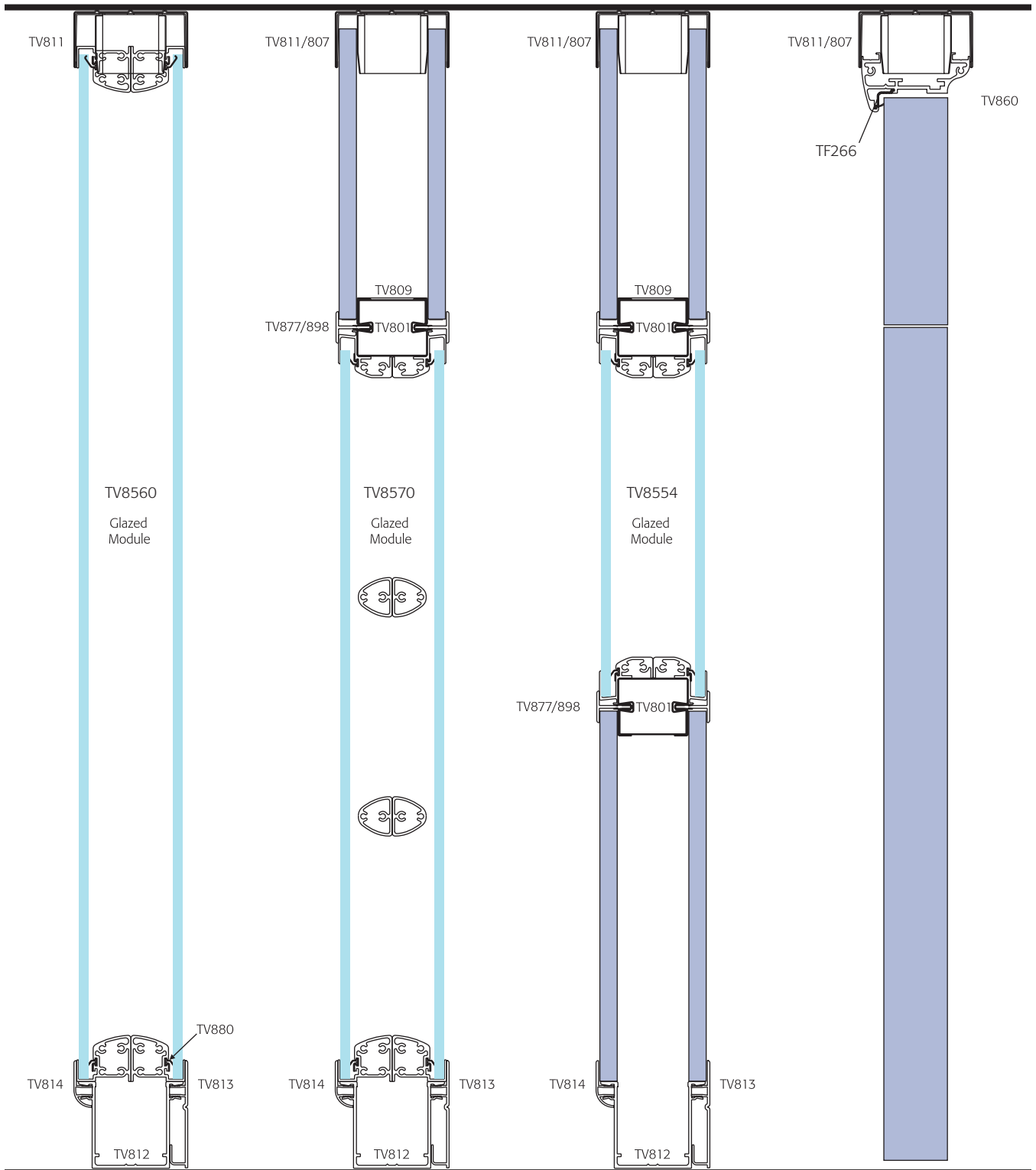

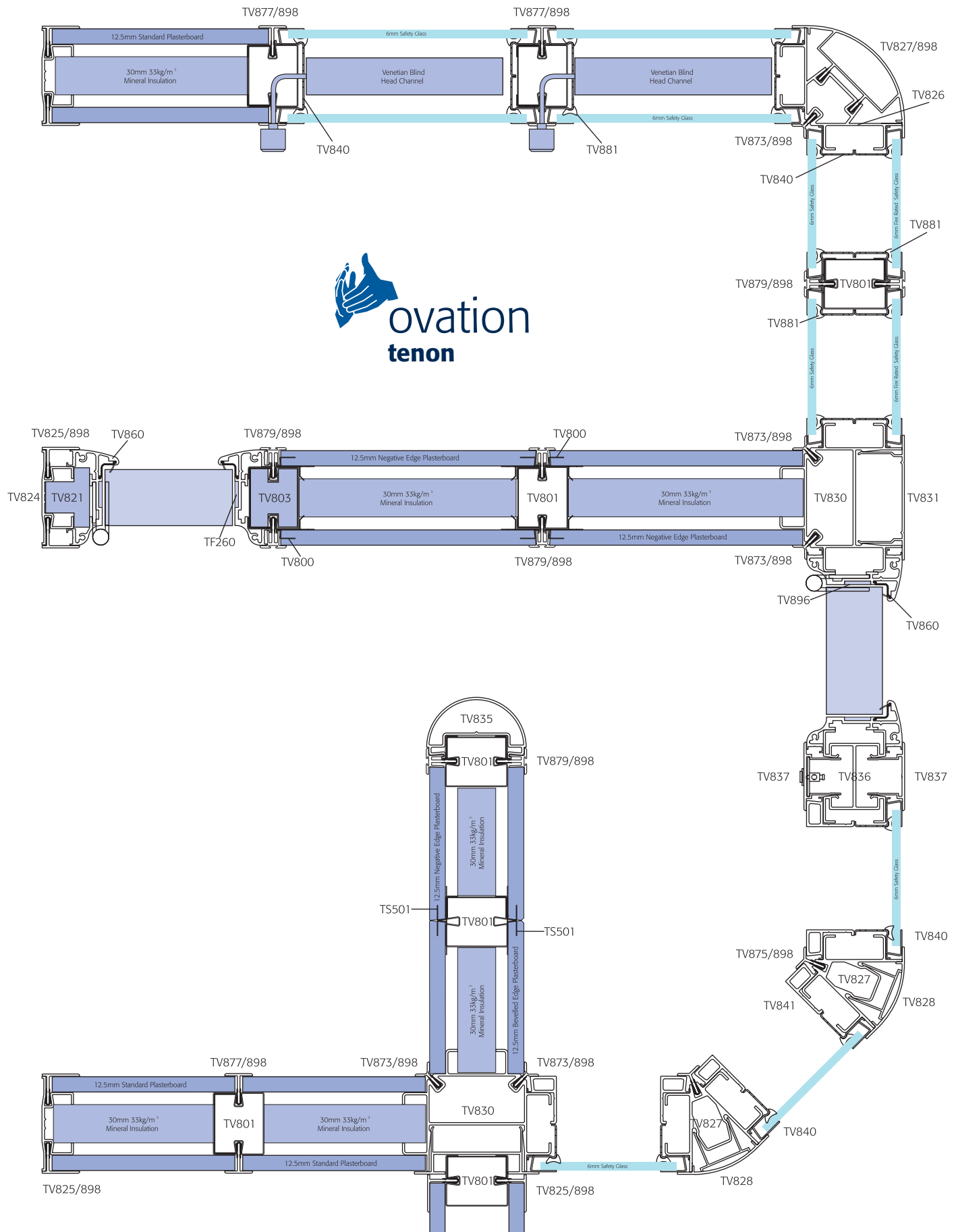

Elevation Details

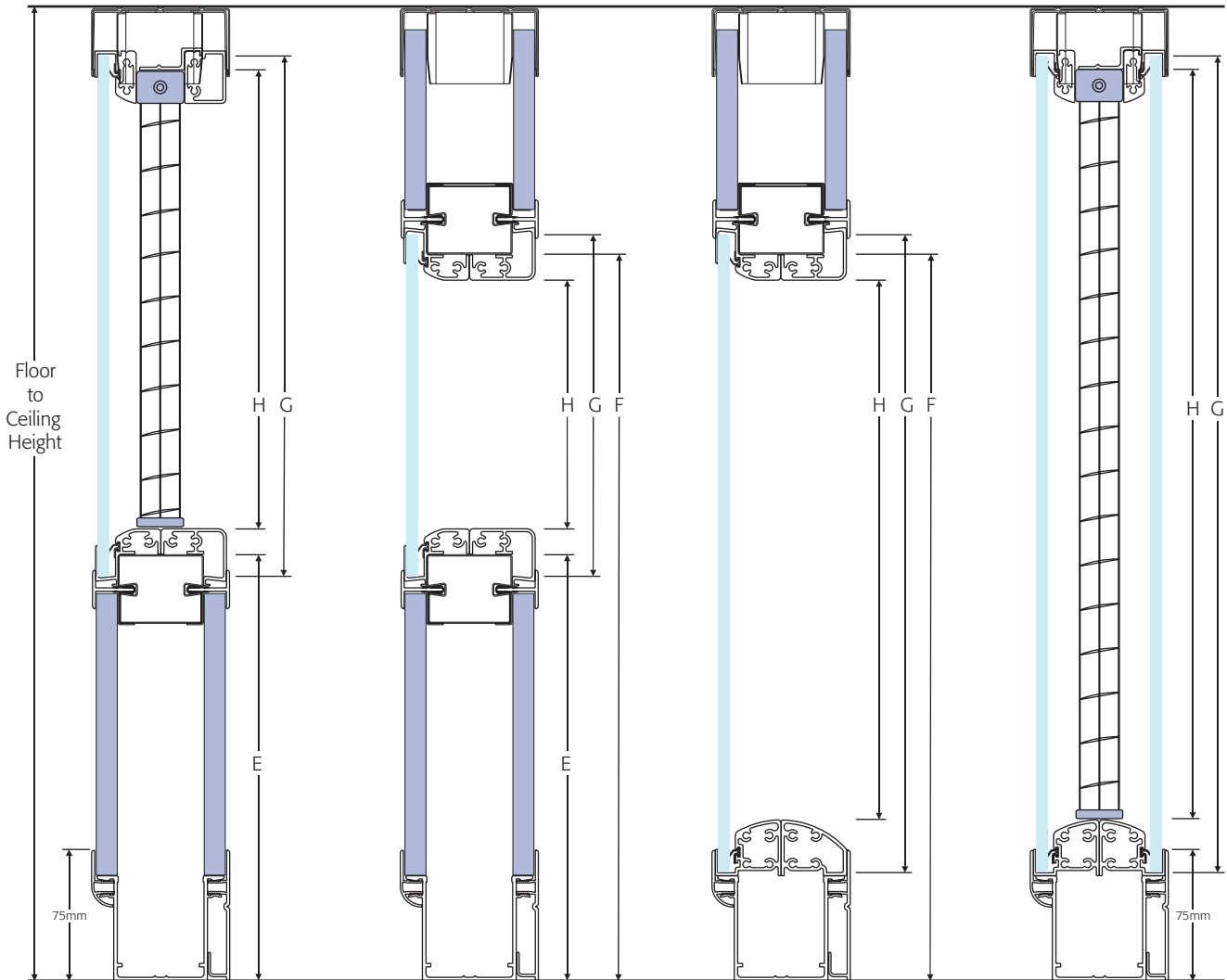
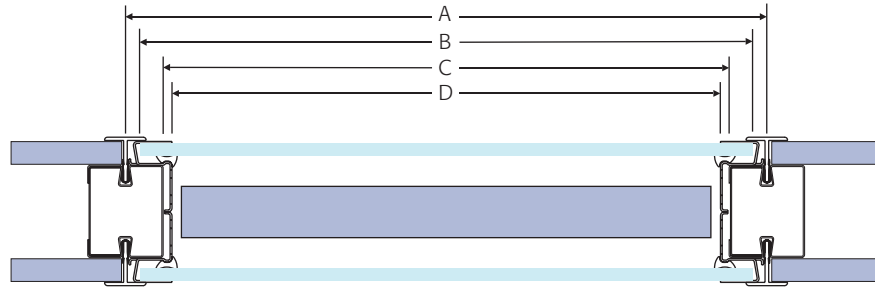

Plan Details



	WIDTH			HEIGHT					
	STANDARD MODULE			HALF GLAZED* (1200x 1200)	HALF GLAZED** (1500x 1200)	MID GLAZED (800x 1200 nom)	MID GLAZED (1000x 1200 nom)	GLAZED TO DOOR HEAD (1900x 300 nom)	FULL HEIGHT WITH 75MM SKIRTING
DIM A	1209mm	Dado Transom Height	DIM E	1220mm	1220mm	1220mm	1020mm	N/A	N/A
DIM B	Dim A - 15mm	Door Head Transom Height	DIM F	N/A	N/A	Door Height + 18mm	Door Height + 18mm	Door Height + 18mm	N/A
DIM C	Dim A - 40mm	Glass Dimension	DIM G	1163mm	1463mm	Dim F - 1198mm	Dim F - 998mm	Dim F - 52mm	Floor to Ceiling Height - 91mm
DIM D	Dim A - 50mm	Blind Aperture Dimension	DIM H	1129mm	1429mm	Dim F - 1249mm	Dim F - 1049mm	Dim F - 107mm	Floor to Ceiling Height - 128mm

* Assumes a floor to ceiling height of 2400mm

** Assumes a floor to ceiling height of 2700mm

Glass can be ordered at the sizes included in the above table, however deduct normal tolerances for Venetian blinds

Glazing Setting Out Details

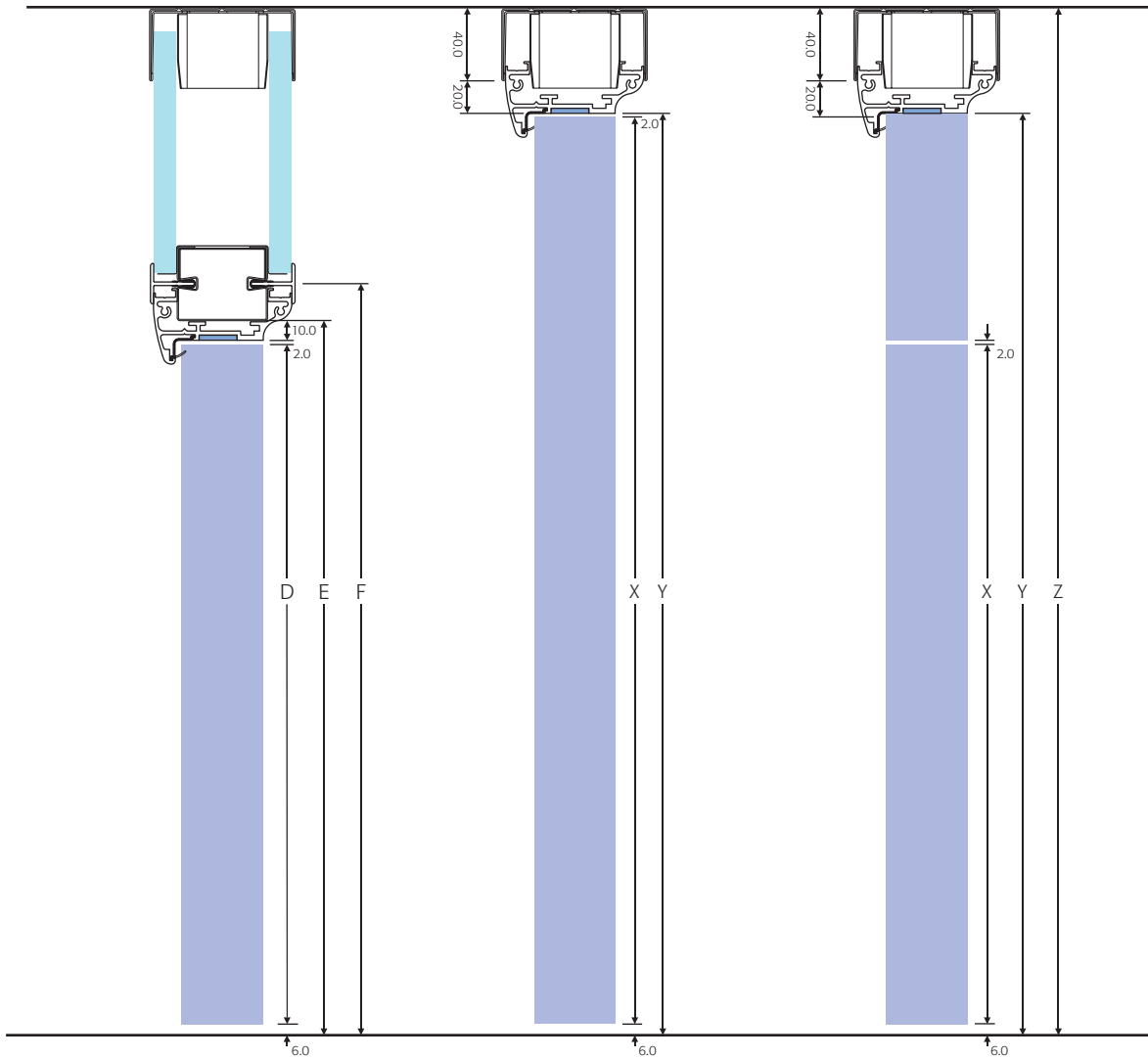
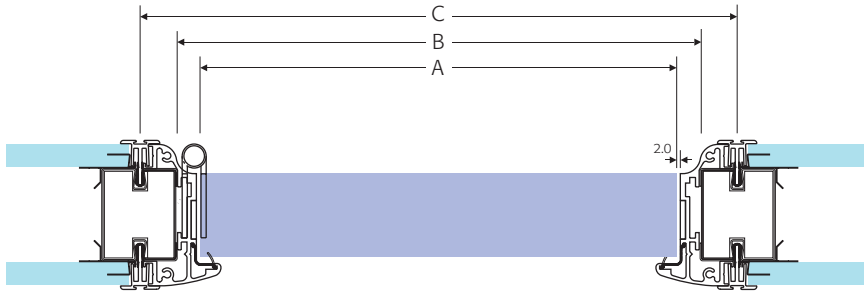

	WIDTH			
	SINGLE		DOUBLE	
	METRIC DOOR	IMPERIAL DOOR	METRIC DOOR	IMPERIAL DOOR
DIM A	826mm	838mm	1652mm	1676mm
DIM B	Dim A + 24mm	Dim A + 24mm	Dim A + 27mm	Dim A + 27mm
DIM C	Dim A + 64mm	Dim A + 64mm	Dim A + 67mm	Dim A + 67mm

	HEIGHT		
	SINGLE	IMPERIAL DOOR	FULL - O/P
	METRIC DOOR	IMPERIAL DOOR	METRIC / IMPERIAL DOOR
DIM D	2040mm	1981mm	DIM X Dim Z - 68mm
DIM E	Dim D + 18mm	Dim D + 18mm	DIM Y Dim Z - 60mm
DIM F	Dim D + 38mm	Dim D + 38mm	DIM Z Floor to Ceiling Height

Door Frame Setting Out Details



TV 800 OVATION PANEL EDGE CLIP
used for the fixing of all panels where trims TV870/871/878/879 are used.



TV 801 49mm OVATION STUD SECTION
used for all vertical framework except where earthed cable management is required. Section comes boxed with channel section TV801C.



TV 803 49mm OVATION FEATURE DOOR STUD SECTION
used for all framework around door frames in conjunction with timber infill TV805.



TV 806 HEAD CHANNEL SPLICING PLATE
for use where head channel section TV810 is joined together.



TV 807 STUD HEAD RETAINER BRACKET
push fit bracket used to locate stud sections TV801 and TV803 within head channel TV810. Fixing free.



TV 808 TRANSOM / ALUMINIUM POST BRACKET
push fit bracket used to secure transoms and aluminium posts. Screw fixed.



TV 810 78mm STEEL HEAD CHANNEL
used for all fire and non-fire rated applications as an abutment channel.



TV 812 ALUMINIUM RECESSED BASE SECTION
Can be used either with flush skirting section TV813 or curved skirting section TV814.



TV 813 75mm ALUMINIUM FLUSH CLIP ON SKIRTING
push fit skirting section used to accommodate cable management within base section TV812.



TV 814 ALUMINIUM RADIUS CLIP ON SKIRTING
push fit radius skirting section.



TV 815 75mm ALUMINIUM FACE FIXED SKIRTING
used in conjunction with steel clamping section TF275.



TV 816 90° JUNCTION PRE-FABRICATED HEAD CHANNEL



TV 817 135° JUNCTION PRE-FABRICATED HEAD CHANNEL



TV 824 ALUMINIUM ABUTMENT MAIN SECTION
used at wall abutments in conjunction with clip on section TV825/TV898 to allow easy fitting of the last solid/glazed panel.



TV 825 ALUMINIUM ABUTMENT CLIP IN SECTION.
used at wall abutments in conjunction with main section TV824 to allow easy fitting of the last solid/glazed panel used in conjunction with steel spring clip TV898.



TV 826 ALUMINIUM 90° CORNER POST MAIN SECTION
used with push fit cover plate section TV827.



TV 827 ALUMINIUM 90° CORNER PUSH FIT COVER PLATE
used in conjunction with main post section TV826.



TV 828 ALUMINIUM 135° CORNER POST MAIN SECTION
used with push fit cover plate section TV829.



TV 829 ALUMINIUM 135° CORNER PUSH FIT COVER PLATE
used in conjunction with main post section TV830.



TV 830 ALUMINIUM 3 WAY POST MAIN SECTION
used in conjunction with flush cover plate TV831, Can also be used with section TV832 to create a 4 way post.



TV 831 ALUMINIUM 3 WAY FLUSH COVER PLATE
pushfit section used with 3 way post TV830.



TV 832 ALUMINIUM 4 WAY CONVERTER SECTION
push fit section used with 3 way post TV830 to create a 4 way post. Can also be used as a feature cover plate.



TV 833 ALUMINIUM 'Y' POST INSERT
(FOR FULL PANEL DEMOUNTABILITY)
push fit section used with 90° corner post TV826 to create a Y junction.



TV 835 ALUMINIUM END CAPPING SECTION
used to finish off the fair end of a partition or as a capping section.



TV 836 CABLE MANAGEMENT POST
used in conjunction with push fit, over plate TV837 to provide, cable management for electrical switches and remote blind controls.



TV 837 CABLE MANAGEMENT PUSH FIT COVER PLATE
used with post TV836.



TV 840 STEEL VERTICAL GLAZING SECTION
used vertically in all glazing frames.



TV 841 ALUMINIUM VERTICAL BLANKING SECTION
used vertically in all offset glazing blanking frames.



TV 842 ALUMINIUM HORIZONTAL HEAD/BASE GLAZING SECTION
used horizontally at base and head in full height glazing frames.



TV 843 ALUMINIUM HORIZONTAL STOCK HEIGHT GLAZING SECTION
used horizontally at base and head of all stock height glazing frames.



TV 844 ALUMINIUM HEAD GLAZING SECTION FOR BLINDS
used horizontally at head of glazing frames where integral venetian blinds are fitted. Used in conjunction with fixing plate TV844A.



TV 845 ALUMINIUM HORIZONTAL HEAD BLANKING SECTION
used horizontally at the bead of all blanking frames.



TV 846 ALUMINIUM STOCK HEIGHT BLANKING SECTION
used horizontally at base and head of all stock height blanking frames.



TV 847 ALUMINIUM HORIZONTAL BASE BLANKING SECTION
used horizontally at base and head of all blanking frames.



TV 848 ALUMINIUM INTEGRAL TRANSOM SECTION
used horizontally within glazing and blanking frames to create a banded glazing effect.



TV 849 ALUMINIUM HEAD BLANKING SECTION FOR BLINDS
used horizontally at head of blanking frames where integral venetian blinds are fitted. Used in conjunction with fixing plate TV844A.



TV 860 75mm DOOR FRAME SECTION
frame section used in door frame packs. Frame is milled for and including 3 self oiling hinges, lockbox, door seal and aluminium mitre cleat.



TV 872 PLASTIC 90° CORNER POST TRIM SECTION
plastic trim section used to finish off the internal angle of the 90° corner post.



TV 873 ALUMINIUM 90° CORNER POST TRIM SECTION
aluminium trim section used to finish off the internal angle of the 90° corner post. Used in conjunction with spring steel clip section TV898 this section should be used in lieu of TV872 in all fire rated applications.



TV 874 PLASTIC 135° CORNER POST TRIM SECTION
plastic trim section used to finish off the internal angle of the 135° corner post.



TV 875 ALUMINIUM 135° CORNER POST TRIM SECTION
aluminium trim section used to finish off the internal angle of the 135° corner post. Used in conjunction with spring steel clip section TV898 this section should be used in lieu of TV874 in all fire rated applications.



TV 876 PLASTIC INTERPANEL 'T' SECTION
plastic section used to conceal the edge of a cut panel between modules and as a door frame trim to fall in line with the push fit skirting sections. Can be used as a joint trim with square edge plasterboards and other square edge panel types.



TV 877 ALUMINIUM INTERPANEL 'T' SECTION
aluminium trim section used to conceal the edge of a cut panel between modules and as a doorframe trim to fall in line with the push fit skirting sections. Used in conjunction with spring steel clip section TV898 this section should be used in lieu of TV876 in all fire rated applications. Can also be used as a joint trim with square edge plasterboards and other square edge panel types.



TV 878 PLASTIC INTERPANEL OMEGA
plastic trim section that can be used to retain standard solid and glazed panels but can also be used as a cut panel trim. Section is used in conjunction with colour contrast strip TV884-TV889.



TV 879 ALUMINIUM INTERPANEL OMEGA
aluminium trim section that can be used to retain standard solid and glazed panels but can also be used as a cut panel trim. Section is used in conjunction with colour contrast strip TV884-TV889 and spring steel clip section TV898. This section should be used in lieu of TV878 in all fire rated applications.



TV 880 CLEAR PVC CAPTIVE GLAZING GASKET
used in all horizontal glazing sections to suit 6mm to 9mm glass.



TV 881 CRYSTAL CLEAR WEDGE GLAZING GASKET
used vertically in glazing section TV840 to suit 6mm to 7mm glass.



TV 884 PLASTIC COLOUR INFILL
used to provide a colour contrast in trim section TV878/879.



TV 890 DOOR HINGE
self oiling door hinge for use with doors up to a weight of 60kg.



TV 891 DOOR FRAME BRACKET SECTION
used to ensure an effective join on mitred frames.



TV 895 20 x 2.5mm INTUMESCENT STRIP
used in door frames in all fire rated applications.



TV 896 DUMMY INTUMESCENT STRIP
used in door frames in all non-fire rated applications to conceal fixings.











TV 898 STEEL SPRING CLIP
used to secure all aluminium trim sections.

		Performance Summary					
		SYSTEM			75mm Ovation		
FIRE		CONSTRUCTION			One layer of 12.5mm plasterboard fitted either side of Tenon 50mm stud with 50mm mineral fibre slab in cavity		
30 Minutes Integrity 30 Minutes Insulation	SOLID	TV879 Omega Trim				4	
	SOLID	Bevelled Joint				4	
	SOLID	'T' Trim*				4	
	SOLID	Pencil-Line Joint				4	
	SOLID	Taped Joint				4	
30 Minutes Integrity**	GLAZED	Single Glazing				4	
	GLAZED	Double Glazing				4	
30 Minutes Integrity	SOLID	Single Door				4	
	SOLID	Double Door				4	
	SOLID	Hospital Door				4	
	SOLID	Full Height Door				4	
	SOLID	Full Height Door & OP				4	
* Door modules only ** Pyroshield safety glass, Pyran only.							
ACOUSTIC / STRUCTURAL	Stud Size	Plasterboard / Glass Type	Plasterboard / Glass Thickness	Single / Double	Insulation Type	dB Rating	Maximum Construction Height
75mm - Solid	49mm	Standard	12.5mm	Single Skin	None	34dB(RW)	3000mm
	49mm	Neg/Bev Edge	12.5mm	Single Skin	None	37dB(RW)	3000mm
	49mm	Standard	12.5mm	Single Skin	50mm 45kg/m ³	40dB(RW)	3000mm
	49mm	Neg/Bev Edge	12.5mm	Single Skin	50mm 45kg/m ³	43dB(RW)	3000mm
75mm - Glazed	49mm	Laminated	6.4mm	Single Glazed	N/A	33dB(RW)	3000mm
	49mm	Acoustic Lam	6.8mm	Single Glazed	N/A	35dB(RW)	3000mm
	49mm	Lam/Tough	6.4/6.0mm	Double Glazed	N/A	38dB(RW)	3000mm
	49mm	Acoustic Lam	7.0/9.0mm	Double Glazed	N/A	42dB(RW)	3000mm
Door Module						30dB(RW)	



Ovation is only one of the systems that forms the Tenon range. Other products in the range include:

- | | |
|--|--|
|  fire & sound |  washrooms |
|  flexplus |  operable walls |
|  scion |  vitrage |
|  wall store |  accessories |

ESEPROJECTS
Design, Supply & Install Services

Wensum Works,
150 Northumberland Street
Norwich, Norfolk, NR2 4EE

Phone: +44 (0)1603 629956
Fax: +44 (0)1603 630113

Email: sales@eseprojects.co.uk
Web: www.eseprojects.co.uk