

Thank you for purchasing a Sealey product. Manufactured to a high standard this product will, if used according to these instructions and properly maintained, give you years of trouble free performance.



**IMPORTANT: PLEASE READ THESE INSTRUCTIONS CAREFULLY. NOTE THE SAFE OPERATIONAL REQUIREMENTS, WARNINGS & CAUTIONS. USE THE PRODUCT CORRECTLY AND WITH CARE FOR THE PURPOSE FOR WHICH IT IS INTENDED. FAILURE TO DO SO MAY CAUSE DAMAGE AND/OR PERSONAL INJURY AND WILL INVALIDATE THE WARRANTY. PLEASE KEEP INSTRUCTIONS SAFE FOR FUTURE USE.**

### 1. SAFETY INSTRUCTIONS

- ✓ Ensure that the spreader is in sound condition and good working order before use.
- ✓ Ensure that the operator is fully trained and competent to operate the prime mover before attaching and using the spreader.
- ✓ Ensure that all chemical safety instructions are adhered to when handling products for use in the spreader. A full range of personal safety equipment is available from your Sealey dealer.
- ✓ Always distribute the load evenly.
- ✓ Ensure all non essential personnel keep a safe distance when the spreader is in use.
- ✓ Replace or repair damaged parts. *Use only recommended parts. Unauthorised parts may be dangerous and will invalidate the warranty.*
- ✓ Keep hands and feet away from moving parts.
- ✗ **DO NOT** overload the spreader - see Specification.
- ✗ **DO NOT** leave unattended, especially when loaded, unless the wheels are chocked or the spreader is otherwise secured.
- ✗ **DO NOT** allow others to ride on the spreader.
- ✗ **DO NOT** allow untrained personnel to use the spreader.
- ✗ **DO NOT** use the spreader for purposes other than for which it is designed.
- ✗ **DO NOT** operate the spreader when you are tired or under the influence of alcohol, drugs or intoxicating medicines.
- ✗ When loaded, **DO NOT** operate the spreader over edges, rough surfaces etc. where the spreader is at risk of overturning.
- ☐ **WARNING!** Failure to comply with these instructions may result in damage to spreader or other property and/or personal injury.

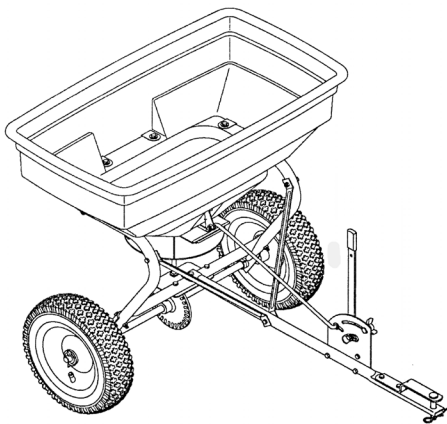

### 2. INTRODUCTION

Manufactured with a strong tubular steel frame and polypropylene dispensing hopper. Pin hitch design attaches to ride-on lawnmowers, can be converted to ball hitch using Model No. TB36. Fitted with aluminium gear, rain cover, pneumatic tyres and adjustable feed system. Includes hopper screen to ease spreader flow and filter out unwanted contaminants. Sprays in 360° motion to cover a large area. Suitable for a variety of horticultural agents, including grit, seed, salt, fertiliser and weed killer.

### 3. SPECIFICATION & CONTENTS

Model No. ....	SPB57T
Capacity (Weight) .....	57kg
Capacity (Volume) .....	60ltr
Spread .....	3-3.6mtr
Weight .....	11.6kg
Dimensions (W x D x H) .....	680 x 980 x 790mm

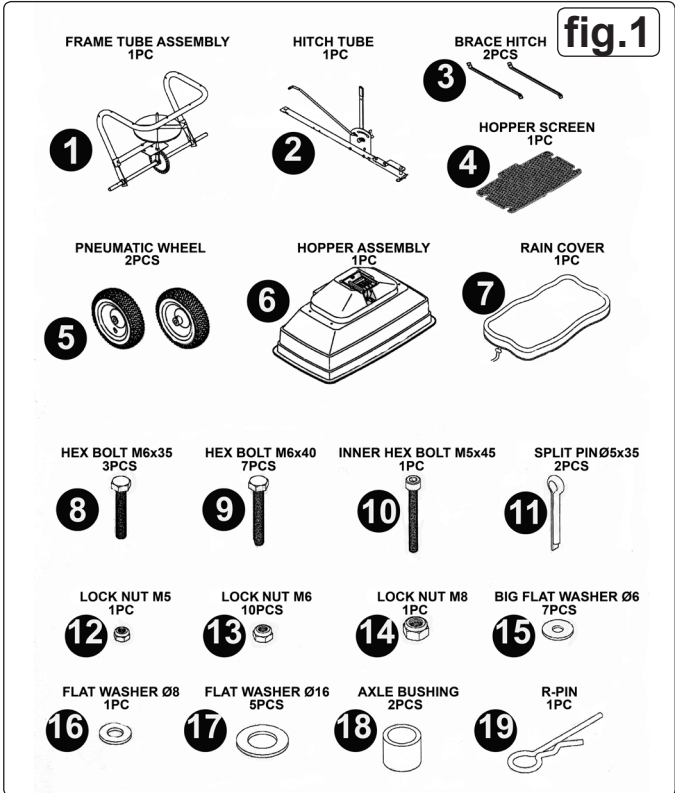

### 4. ASSEMBLY

- 4.1. Check contents against fig.1 above, if anything is missing or damaged contact your local Sealey dealer.
- 4.2. Referring to fig.2, place an axle bush (18) onto the axle of the frame tube assembly(1).
- 4.3. Attach the pneumatic wheel (5) then a Ø16 flat washer (17) to the mounting tube axle. Secure with split pin (11) and repeat procedure for the other side. Additional Ø16 flat washers (17) are provided to adjust the spacing between the axle bushing (18) and the pneumatic wheel (5).
- 4.4. Rotate one pneumatic wheel (5) so that the hole on the inside of the wheel boss aligns with the corresponding hole in the axle tube. Insert inner hex bolt M5x45 (10) through the axle tube and secure with lock nut M5 (12) as shown in figure 2.

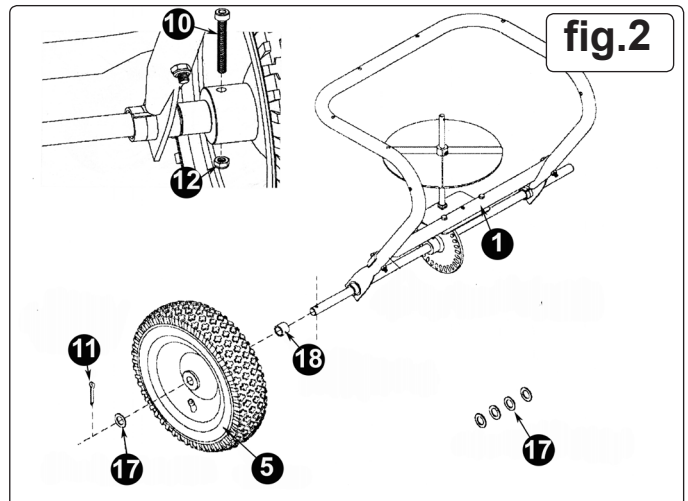

- 4.5. Attach the hitch tube (2) to the frame tube assembly tube (1) using hex bolt M6x40 (9), big flat washer M6 (15) and M6 lock nut (13) as shown in figure 3. At this stage do not fully tighten the nut and bolt.

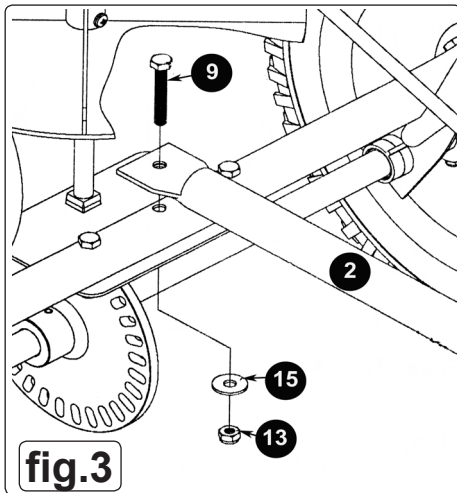

- 4.6. Attach one brace (3) to either side of the hitch tube (2) using hex bolt M6x35 (8) and M6 lock nut (13) as shown in figure 4. Do not fully tighten the nut at this stage

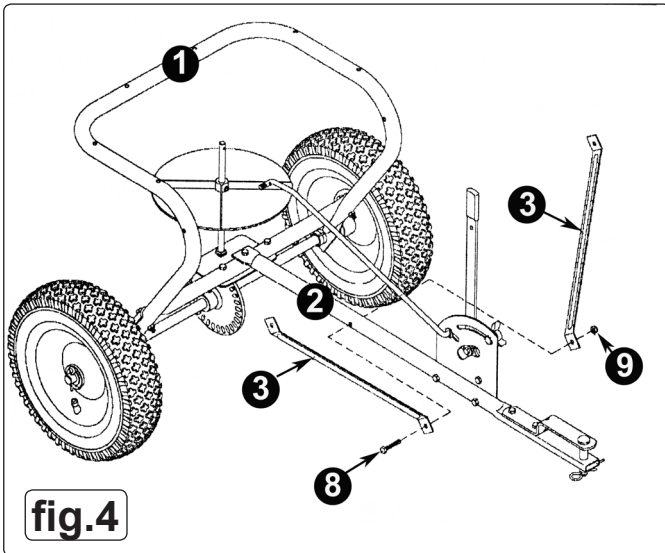

- 4.7. Attach the other ends of the braces (3) to the frame tube assembly (1) using hex bolt M6x35 (8) and M6 lock nuts (13) as shown in figure 5.

- 4.8. All nuts and bolts used for the braces (3) can now be fully tightened

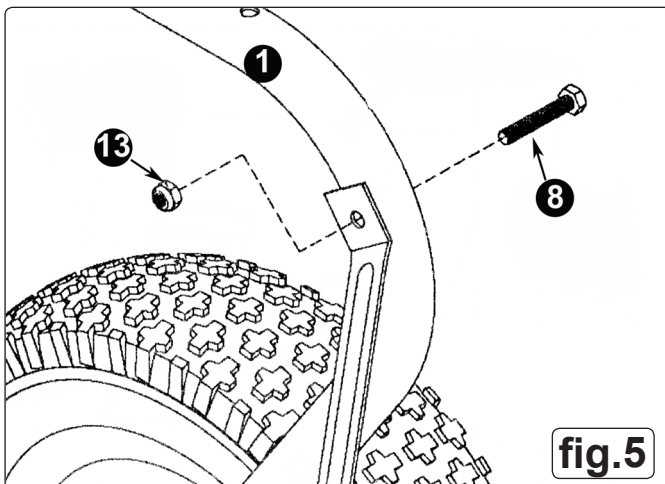

- 4.9. Place the hopper (6) over the frame tube assembly (1) so that the shaft protruding from the impeller on the frame tube assembly locates into the swivel bush on the base of the hopper.
- 4.10. Align the six bolt holes in the hopper assembly with the six bolt holes on the frame tube assembly and fit the Hex Bolts M6x40 (9) with the big flat washers M6 (15) at the bolt heads. Loosely attach the M6 lock nuts (13) as shown in figure 6. Adjust the hopper assembly over the frame tube assembly until the impeller is free to rotate without any resistance. Fully tighten the nuts and bolts securing the hopper assembly to the frame tube assembly.
- 4.11. Attach the R-pin (19) to the shaft protruding above the impeller as shown in figure 7.

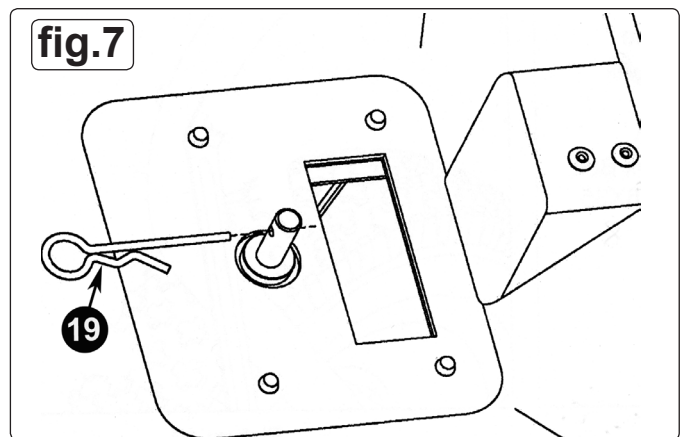
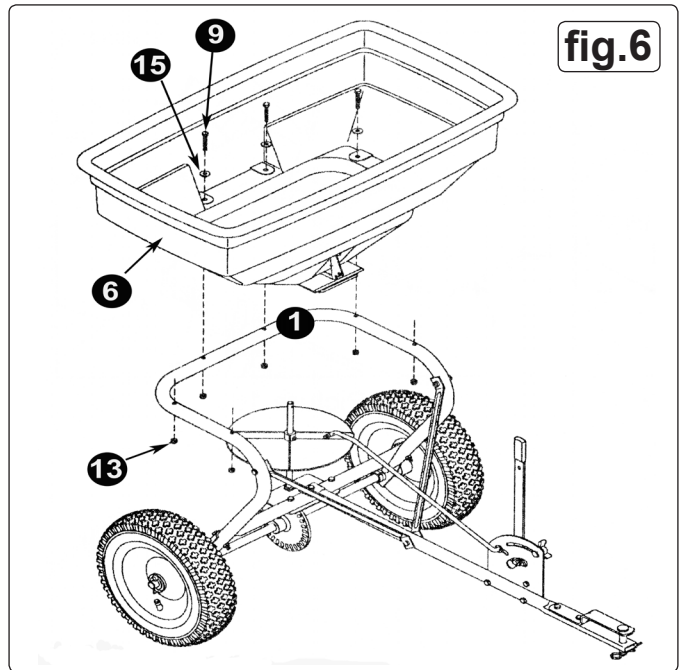

- 4.12. Attach a Ø8 flat washer (16) over the loose end of the adjustable connection rod and insert the rod through the hole in the fixing plate at the base of the hopper and secure with a M8 lock nut (14) as shown in figure 8.
- 4.13. Place the hopper screen (4) into the hopper (6) so that it sits squarely on the base.
- 4.14. The spreader is now fully assembled and ready for use.

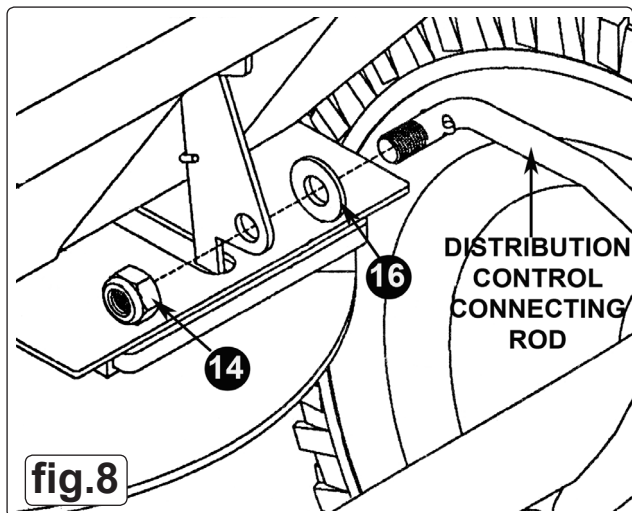

## 5. OPERATION

- 5.1. Read the Safety Instructions in Section 1 before operating the spreader.
- 5.2. Secure the spreader onto the prime mover using the towing pin on the hitch tube (2). Secure the towing pin with the R-pin provided. The spreader can be converted to use a ball hitch by fitting a Sealey Ø50mm Towing Hitch, Model No. TB36, available from your Sealey dealer.
- 5.3. Load the product into the hopper, ensuring that it is evenly distributed and the maximum capacity of the spreader is not exceeded. When handling hazardous products it is important to first read the safety data sheet and take necessary safety precautions. A full range of personal safety equipment is available from your Sealey dealer.
- 5.4. The towing speed will affect the rate of flow from the spreader. It is advisable to operate the spreader at lower speeds for a more effective flow of the product.
- 5.5. The adjustable feed system is controlled by movement of the handle on the hitch tube (2). Operate the spreader at the desired speed and adjust the handle either forwards or backwards until a satisfactory rate of flow is achieved. A locking device is provided on the gauge to allow the optimum flow required to be maintained.
- 5.6. Clean the spreader thoroughly after use, paying particular attention to the area around the adjustable feed system and the impeller.

## 6. MAINTENANCE

- 6.1 After each use clean material out of hopper.
  - 6.1.1 Rinse/dry inside and outside of spreader after each use.
  - 6.1.2 Before operating make sure that the tyres are inflated to the correct pressure.
  - 6.1.3 Periodically check all fastenings are tight.
  - 6.1.4 Annually clean and lightly lubricate parts.
  - 6.1.6 To avoid damaging the spreader never exceed the rated load capacity of 57kg.
- 6.2 **STORAGE.**
  - 6.2.1 Before storing ensure that the spreader is clean and dry.
  - 6.2.2 Store indoors or in a protected area during severe weather and in the winter months.
  - 6.2.3 Never allow material to stay in the hopper for extended periods of time.

<b>(CHART 'A') SQUARE FOOT COVERAGE PER BAG (LBS/1000 SQ.FT)</b>			
<b>WEIGHT OF BAG (LBS)</b>	<b>5000 SQ.FT COVERAGE</b>	<b>10000 SQ.FT COVERAGE</b>	<b>15000 SQ.FT COVERAGE</b>
5	1.0lb	0.5lb	0.3lb
10	2.0lb	1.0lb	0.7lb
15	3.0lb	1.5lb	1.0lb
20	4.0lb	2.0lb	1.3lb
25	5.0lb	2.5lb	1.7lb
30	6.0lb	3.0lb	2.0lb
35	7.0lb	3.5lb	2.3lb
40	8.0lb	4.0lb	2.3lb
45	9.0lb	4.5lb	3.0lb
50	10.0lb	5.0lb	3.3lb
55	11.0lb	5.5lb	3.7lb

<b>(CHART 'B') SPREADER SETTINGS/SPREADER WIDTHS</b>					
<b>MATERIALS TO BE USED</b>	<b>LBS/1000 SQ.FT</b>	<b>SPREADER SETTING</b>	<b>SMALL PARTICLE SPREAD</b>	<b>MEDIUM PARTICLE SPREAD</b>	<b>LARGE PARTICLE SPREAD</b>
<b>GRIT</b> <b>SEED</b> <b>FERTILISER</b> <b>WEED KILLER</b> <b>E.T.C.</b>	1	5	5-6 ft	6-9 ft	9-12 ft
	2	8	5-6 ft	6-9 ft	9-12 ft
	3	10	5-6 ft	6-9 ft	9-12 ft
	4	13	5-6 ft	6-9 ft	9-12 ft
	5	15	5-6 ft	6-9 ft	9-12 ft
	6	18	5-6 ft	6-9 ft	9-12 ft
	7	20	5-6 ft	6-9 ft	9-12 ft
	8	23	5-6 ft	6-9 ft	9-12 ft
	9	25	5-6 ft	6-9 ft	9-12 ft
	10	28	5-6 ft	6-9 ft	9-12 ft
	11	30	5-6 ft	6-9 ft	9-12 ft

**NOTE:** It is our policy to continually improve products and as such we reserve the right to alter data, specifications and component parts without prior notice.

**IMPORTANT:** No liability is accepted for incorrect use of this product.

**WARRANTY:** Guarantee is 12 months from purchase date, proof of which will be required for any claim.

**INFORMATION:** For a copy of our catalogue and latest promotions call us on 01284 757525 and leave your full name, address and postcode.

